



Close Control Plug Fan Range



Engineering Data Manual 50/60Hz

Index

Description	Page
YORK Company Profile	3
This YORK Product Range	3
Other YORK Close Control Products	3
Equipment Nomenclature	4
Indoor Unit Dimensions and Weights	4
Condensers - Dimensions and Weights	5
Drycoolers - Dimensions and Weights	6
Guide Specifications	7
General Engineering Details	11
Air Cooled System Schematic	12
Water/Glycol Cooled System Schematic	13
Chilled Water Cooled System Schematic	14
Air Cooled Units - Cooling Capacities 50/60Hz	15
Water Cooled Units - Cooling Capacities 50/60Hz	16
Glycol Cooled Units - Cooling Capacities 50/60Hz	17
Chilled Water Cooled Units - Cooling Capacities 50/60Hz	18
Electrical Details - 400V/ 3Ph / 50Hz	19
Electrical Details - 220V/ 3Ph / 60Hz	20
Electrical Details - 380V/ 3Ph / 60Hz	21
Electrical Details - 460V/ 3Ph / 60Hz	22

While every precaution has been taken to ensure accuracy and completeness in this manual, YORK assumes no responsibility, and disclaims all liability for damages resulting from use of this information or for any errors or omissions.

YORK COMPANY PROFILE

YORK – a Johnson Controls company, designs, manufactures, sells and services: heating and air conditioning systems and compressors for residential, commercial and industrial markets, gas compression equipment for industrial processing, industrial and commercial refrigeration equipment.

The company manufactures a wide range of air conditioning products including fan coil units, close control units, under-floor air distribution systems, telecom shelter units, variable air volume systems, air handling units, mini split systems, packaged air conditioners, roof top units, water cooled and air cooled chillers, heat pumps and absorption chillers. We also manufacture a variety of compressors including hermetic, scroll, reciprocating, screw and centrifugal types.

YORK products are installed in nuclear submarines operating deep in the ocean and in South African gold mines in the depth of the earth. Eurotunnel, which has the world's largest chilled water system, is served by YORK chillers as does the world's tallest building the twin tower Petronas complex in Malaysia.

Other notable global installations are the Sydney Opera House, Charles de Gaulle and Jeddah Airports, most of the commercial buildings dominating the Hong Kong skyline, the Islamic University in Riyadh, the UK Houses of Parliament, the Kremlin, the United States Capitol and the Pentagon in Washington DC, the Eiffel Tower restaurant and the Prophets Mosque in Medina: all these and numerous installations world-wide. In our own way YORK influences the weather by providing snow on demand at the world's major ski resorts.

THIS YORK PRODUCT RANGE

CLOSE CONTROL PLUG FAN UNITS

The EDPAC Close Control Plug Fan Range of Air Cooled Direct Expansion units are precision environmental control units designed for 24 hour, year-round use. The unit simultaneously controls air temperature, air humidity, air distribution and air cleanliness in the conditioned space. It is fitted with a central microprocessor controller which monitors air temperature/humidity and air cleanliness and ensures accurate stepped response to room load changes. To maximise energy efficiency, all units are fitted with wide surface area coils, compliant scroll compressors and backward curved radial fans. Sound levels are kept to a minimum with double skin panels (optional), a unique wide area air chamber, coil mounted filtration and fully isolated compressor compartment. All major components are fully serviceable from the front.

OTHER YORK CLOSE CONTROL PRODUCTS

CLOSE CONTROL MODULAR UNITS

Modular units for computer room and telecom applications with capacities from 10 to 120kW. Units are available in Upflow and Downflow configurations with top, bottom, front and rear return options. Cooling media available are direct expansion using Air or Water/Glycol and Chilled Water.

CLOSE CONTROL AIR COOLED TWIN CIRCUIT UNITS

The Close Control Twin Circuit range comprises 3 sizes providing nominal capacities of 30, 40, 50, 60, 70 & 80 in 10kW increments. Units are twin circuit in a single frame and are available in Upflow and Downflow configurations. Cooling is by air cooled direct expansion only.

DCS / FCS CHILLED WATER UNITS

The DCS / FCS range of Close Control Chilled Water units comprises 3 sizes providing nominal capacities of 60, 80 & 100 kW. Units are available in Upflow and Downflow configurations.

EQUIPMENT NOMENCLATURE

The EDPAC Close Control Plug Fan Range of Air Cooled Direct Expansion units are precision environmental control units designed for 24 hour, year-round use. The unit simultaneously controls air temperature, air humidity, air distribution and air cleanliness in the conditioned space. It is fitted with a central microprocessor controller which monitors air temperature/humidity and air cleanliness and ensures accurate stepped response to room load changes. To maximise energy efficiency, all units are fitted with wide surface area coils, compliant scroll compressors and backward curved radial fans. Sound levels are kept to a minimum with double skin panels (optional), a unique wide area air chamber and coil mounted filtration and fully isolated compressor compartment. All major components are fully serviceable from the front. e.g.: DPA 20 BSWS is a 20kW Single Circuit Unit.

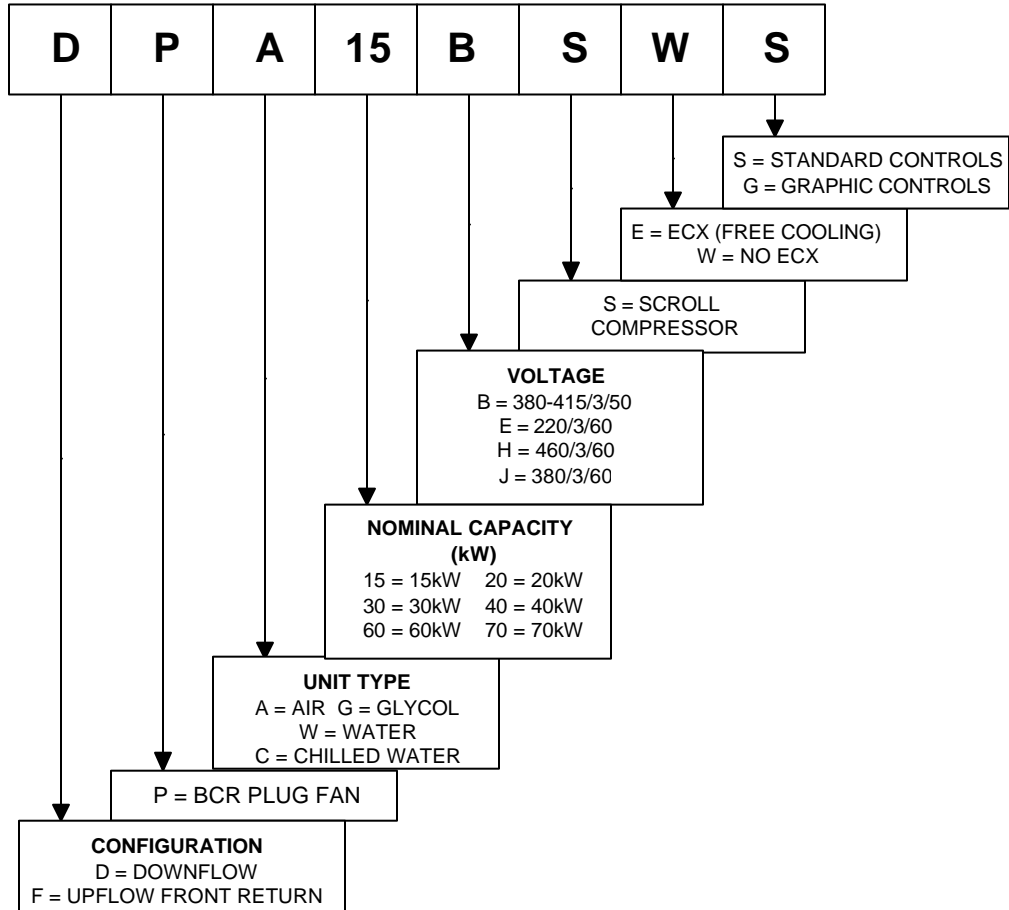

PLUG FAN RANGE DIMENSIONS AND WEIGHTS

PLUG FAN RANGE INDOOR UNITS

Dimensions (mm)

Model	15	20	30	40	60	70	80	100
Width - Chilled Water	800	800	1550	1550	2300	2300	2300	3100
Width - DX Units	1250	1250	2000	2000	2750	2750	2750	N/A
Depth	800	800	800	800	800	800	800	800
Height	1950	1950	1950	1950	1950	1950	1950	1950

Weight (kgs)

Model	15	20	30	40	60	70	80	100
Air Cooled	385	441	720	734	905	915	935	N/A
Water / Glycol Cooled	392	450	734	752	945	960	980	N/A
Chilled Water	276	281	451	461	616	616	631	922

Note

- 100 Model is only available in a Chilled Water version and comes in 2 modules/sections.
- ECX Free Cooling is not available in the Plug Fan Range. For Free Cooling units refer to Close Control Modular Range.

CONDENSERS - DIMENSIONS AND WEIGHTS

CONDENSERS

Model	15	20	30	40	60	70	80
30°C Ambient Selection							
Condenser Model	ACS 402A	ACS 402A	ACS 402A	ACS 402A	ACS 403A	ACS 403B	ACS 502A
Condenser Input Power (kW)	0.4	0.4	0.4	0.4	0.6	0.6	1.6
Condenser Quantity	1	1	2	2	2	2	2
Freefield SPL @ 10m dBA	48	48	51	51	53	53	59
Dimensions W x D (mm)	1380x555	1380x555	1380x555	1380x555	1980x555	1980x555	2042x828
Weight (Kgs) 1No. / 2No.	30/NA	30/NA	30/60	30/60	45/90	49/98	81/162
35°C Ambient Selection							
Condenser Model	ACS 402A	ACS 402B	ACS 402A	ACS 402B	ACS 403B	ACS 502A	ACS 502B
Condenser Input Power (kW)	0.4	0.4	0.4	0.4	0.6	1.6	1.6
Condenser Quantity	1	1	2	2	2	2	2
Freefield SPL @ 10m dBA	48	48	51	51	53	59	59
Dimensions W x D (mm)	1380x555	1380x555	1380x555	1380x555	1380x555	2042x828	2042x828
Weight (kgs) 1No. / 2No.	30/NA	33/NA	30/60	33/66	49/98	81/162	89/178
40°C Ambient Selection							
Condenser Model	ACS 402B	ACS 403A	ACS 402B	ACS 403A	ACS 502B	ACS 502C	ACS 503A
Condenser Input Power (kW)	0.4	0.6	0.4	0.6	1.6	1.6	2.4
Condenser Quantity	1	1	2	2	2	2	2
Freefield SPL @ 10m dBA	48	50	51	53	59	59	61
Dimensions W x D (mm)	1380x555	1980x555	1380x555	1980x555	2042x828	2042x828	2942x828
Weight (kgs) 1No. / 2No.	33/NA	45/NA	33/66	45/90	89/178	97/194	108/216
45°C Ambient Selection							
Condenser Model	ACS 403A	ACS 502A	ACS 403A	ACS 502A	ACS 503A	ACS 503B	ACS 503C
Condenser Input Power (kW)	0.6	1.6	0.6	1.6	2.4	2.4	2.4
Condenser Quantity	1	1	2	2	2	2	2
Freefield SPL @ 10m dBA	50	56	53	59	61	61	61
Dimensions W x D (mm)	1980x555	2042x828	1980x555	2042x828	2942x828	2942x828	2942x828
Weight (kgs) 1No. / 2No.	45/NA	81/NA	55/110	81/162	108/216	125/250	136/272

Notes

1. All Condensers are shipped with mounting feet. When mounted in the horizontal, Condenser models ACS 401 – 403 are 712mm high and Condenser models ACS 501 – 503 are 948mm high.
2. For all air cooled models, a condenser is required per circuit.
3. All condenser data is per circuit except for Freefield SPL which is based on 1No. or 2No. where appropriate.

DRYCOOLERS - DIMENSIONS AND WEIGHTS

DRYCOOLERS

Model	15	20	30	40	60	70	80
30°C Ambient Selection							
Drycooler Model	DCS 502A	DCS 502A	DCS 503A	DCS 503C	DCS 633B	DCS 633B	DCS 633C
Drycooler Input Power (kW)	1.6	1.6	2.4	2.4	7.8	7.8	7.8
Drycooler Quantity	1	1	1	1	1	1	1
Freefield SPL @ 10m dBA	51	51	56	56	64	64	64
Dimensions W x D (mm)	2042x828	2042x828	2942x828	2942x828	4427x1175	4427x1175	4427x1175
Weight (Kgs)	91	91	118	146	367	367	403
35°C Ambient Selection							
Drycooler Model	DCS 502A	DCS 502A	DCS 503A	DCS 632B	DCS 632B	DCS 633C	DCS 633C
Drycooler Input Power (kW)	1.6	1.6	2.4	5.2	5.2	7.8	7.8
Drycooler Quantity	1	1	1	1	1	1	1
Freefield SPL @ 10m dBA	51	51	56	62	62	64	64
Dimensions W x D (mm)	2042x828	2042x828	2942x828	3177x1175	3177x1175	4427x1175	4427x1175
Weight (Kgs)	91	91	118	257	257	403	403
40°C Ambient Selection							
Drycooler Model	DCS 502A	DCS 502A	DCS 503A	DCS 632B	DCS 633B	DCS 633C	DCS 633C
Drycooler Input Power (kW)	1.6	1.6	2.4	5.2	7.8	7.8	7.8
Drycooler Quantity	1	1	1	1	1	1	1
Freefield SPL @ 10m dBA	51	51	56	62	64	64	64
Dimensions W x D (mm)	2042x828	2042x828	2942x828	3177x1175	4427x1175	4427x1175	4427x1175
Weight (Kgs)	91	91	118	257	367	403	403
45°C Ambient Selection							
Drycooler Model	DCS 502A	DCS 502C	DCS 632B	DCS 632C	DCS 633C	DCS 634C	DCS 634C
Drycooler Input Power (kW)	1.6	1.6	5.2	5.2	7.8	10.4	10.4
Drycooler Quantity	1	1	1	1	1	1	1
Freefield SPL @ 10m dBA	51	54	62	62	64	65	65
Dimensions W x D (mm)	2042x828	2042x828	3177x1175	3177x1175	4427x1175	5677x1175	5677x1175
Weight (Kgs)	91	107	257	281	403	525	525

- Notes**
1. All Drycoolers are shipped with mounting feet. When mounted in the horizontal, Drycooler models DCS 501 – 503 are 948mm high and Drycooler models DCS 632 – 634 are 1377mm high.

STANDARD FEATURES

Cabinet

The cabinet frames shall be constructed of formed 1.5mm Zintec steel sections. Paint finish is Epoxy Powder Coated with an "Orange Peel" textured finish. Interior panels to be manufactured from galvanised steel in all cases. Exterior panels are to be as cabinet except in 1.5mm Zintec. Paint Colour to be RAL 9018. The front panels shall be hinged openable by using quarter turn fasteners. Side panels shall be secured to the frame using chrome plated screws. All panels shall be flush fitting, sealed to the frame sections with closed cell foam and insulated with a non-shedding material, which shall be non-combustible, when tested in accordance with B.S. 476 Part 6, 7 & UL 94. The units shall be fully accessible and serviceable from the front.

Cooling Coil

Multi-row (3, 4 or 5 row) constructed from $\frac{3}{8}$ " O/D copper tubes with aluminium fins. Large surface areas ensure high sensible heat ratios and low airside pressure drops, resulting in reduced fan power requirements and noise levels. All DX coils shall be tested to 25 bar and all water coils shall be tested to 10 bar.

DX Units

Scroll compressor, sight glass, filter drier and externally-equalised thermostatic expansion valve. Scroll compressors are fitted with internal overloads, crankcase heaters, rotalocks (service valves) and high and low pressure protection. Pump down is standard on all DX models.

3 Port Control Valve

3 way modulating valve having manual over-ride facility. The control valve is selected to have an authority of 0.3 to 0.5. Valve action is fully proportional ensuring accurate control response. A regulating device is provided on the bypass line for commissioning purposes.

Fans

Backward curved radial fan (plug) positioned to draw air evenly across the entire coil surface area. Exceptional pressure characteristics and very low energy consumption. Fan assembly statically and dynamically balanced and mounted on vibration absorbing mounts. Motor rated to IP55 and fitted with internal thermal overload protection. External static pressure up to 350Pa available.

Electric Heaters

One, two or three stage, high efficiency, electrical reheat elements. Fin-tubular type, phase balanced and protected by an over-temperature thermostat and MCB.

Filtration

Deep pleated EU4 (Eurovent 4/5) or G4 (CEN) panel filters in a rigid frame, mounted on the coil face for maximum surface coverage, low air pressure drop. Monitored by a differential-pressure switch which generates an alarm when a preset pressure drop is exceeded.

Compressors

Compressors shall be Hermetic Scroll type with high efficiency. Back seating isolating valve, high and low pressure switches, motor overload protection and crankcase heaters shall be provided. The compressors shall be mounted on resilient mountings for vibration isolation.

Water Cooled Condensers

The condensers in Water Cooled and Glycol Cooled Units shall be compact brazed plate heat exchangers having a multiplicity of parallel stainless steel pressed plates. The construction shall give high turbulent flows resulting in a compact heat exchanger form with low-pressure drops. The refrigerant head pressure shall be controlled by a 2 port pressure operated water regulating valve.

Humidification

The humidifier shall be of the electrode-boiler type. Features shall include selectable steam output and microprocessor control with alarms and diagnostic facilities. The control system shall allow the use of a wide range of mains water conditions namely: inlet mains water pressure of 1-10bar, total hardness of 15-30 French degrees and water inlet electrical conductivity of 400-800 micro siemens. Unit shall optimise drain down frequency for maximum operational economy.

Electrical Panel

The electrical panel shall be constructed and assembled in compliance with IEC standards with all components VDE/UL approved. All sub circuits are protected by MCB's. The high and low voltage sections shall be segregated and all electrical components touch safe without any exposed contacts.

Microprocessor Controls

All Units shall be fitted as standard with the latest Delta range of DIN rail mounted Microprocessor Controls. The Control System utilises a main Microprocessor Interface Board equipped with a set of terminals necessary to connect the Board to the controlled devices (e.g. valves, compressors, fans, reheats, sensors and humidifiers).

All software is permanently stored in flash RAM and is therefore protected even in the event of a power failure. Unit software is uploaded to the Microprocessor using a RAM key or personal computer. On multi unit sites this quickens unit commissioning. The software can also easily be changed or upgraded on site by qualified service personnel. The Microprocessor also has optional built in Modbus & Bacnet communications and full Windows networking capability. When communicating in Modbus or Bacnet, the protocol converter is in the software and there is no need for external Gateways.

The Microprocessor based Terminal Unit is complete with LCD Display, keypad and LED Indicators allowing the user to easily set the main control parameters (setpoints, differentials and alarm thresholds) and carry out the main working operations (on/off and displaying controlled variables). The Terminal Unit also performs the following functions:

- Initial programming procedure with access protected by a password.
- Possibility of changing the basic operation parameters any time, without stopping the program.
- Indication of any alarm condition via acoustic and visual signals (buzzer and alarm messages appearing on the display).
- Visualisation of the active functions by means of LED indicators.
- Visualisation of the measured variables.

OPTIONAL FEATURES

Delta Graphical Controls

An optional Graphical Terminal Unit is also available. This is a graphical display, LED Backlit with 128 x 64 pixel graphical resolution. This graphical screen allows:

- Configurability of character fonts to represent any alphabet type (Chinese, Arabic etc.)
- Creation of graphic objects for more vivid alarm visualisation
- Display of graphical trends of temperature and humidity.

Floor Stand

Floorstands are shipped flat-pack and need to be assembled on site. They are suitable for raised floor heights of 150mm to 600mm. The legs are notched at 50mm intervals for cutting on site. There is also a final adjustment on the foot of ± 50 mm.

Air Discharge Plenum

For Upflow units which are to be installed in a freeblow situation. Plenum consists of an insulated sheet metal assembly with 3 discharge grilles. Grilles are double deflector type. Plenum colour will match unit colour.

High Efficiency Filters

Higher specification filtration can be provided in addition to the EU4/G4 filters. These filters are of the rigid bag type and have an efficiency of 80% ASHRAE 52/76 (Eurovent EU7/F7). These filters are fitted in the return air side of the unit on a Downflow type and on the supply air side of the unit on an Upflow type.

Fresh Air Kit and Filter

Units can be supplied with a fresh air inlet connection and disposable EU4/G4 filter element. This will admit approximately 3-5% of the recirculated air volume.

Special Colours

Special Colours must be specified when placing orders (quote British standard number, RAL number or other if known).

Double Skin Panels

To reduce the casing radiated "Break Out Noise". These panels consist of an inner solid steel sheet. The inner skins are painted and finished in RAL9018.

Fire/Smoke Detector

A fire/smoke detector can be mounted in the return air path to interface with the unit controls and generate an alarm.

Fire Stat

A fire stat can be located in the return air path within the unit to interface with the unit controls and indicate an alarm

Hot Water Reheat

Units may be fitted with a Low Pressure Hot Water (LPHW) heating coil in place of the standard electrical heating. Water flow through the coil is controlled by a 2 or 3 way on/off valve. Duties of these coils are nominally the same as standard electric heating, based on flow and return hot water temperatures of 82°C and 71°C respectively.

Hot Gas Reheat

The hot gas reheat system is an aluminium fin copper tube heat exchanger, which uses the heat normally rejected in the condenser as reheat during dehumidification thereby reducing the electrical reheat requirements.

Water Detection

A Water Sensor Module is connected to the Unit Microprocessor Control System and supplied with 10m of cable for underfloor water detection. When water is detected the Unit's alarm system is activated.

Condensate Pump

Where, due to location, it is not possible to gravity drain units, a condensate pump can be fitted to collect any condensate and pump it to the nearest convenient drain point (pump duty is 6 l/min Vs 6m head). For units fitted with humidifiers or units requiring a lift in excess of 6m equivalent head, a larger capacity sump pump is available. (pump duty is 6 l/min Vs 10m head).

Top Entry Pipework

The unit pipework can be modified to allow entry/connection of services through the top of the unit.

Hot Gas By-Pass

Air, Water and Glycol models can be fitted with hot gas by-pass compressor capacity control. This consists of a hot gas control valve in the by-pass line between the discharge line of the compressor and the evaporator coil suction header, with the sensing line fitted in the suction line.

Inverters

Energy efficient air volume control, for better load distribution. Fan motor is controlled from a panel mounted electronic inverter drive which enables air volume (and external static) adjustment from zero to full-rated output. The drive also has user-selectable pre-set speeds, internal fault detection and a separate motor overload circuit.

Condenser 3-Way Valves

These valves can be fitted to Water and Glycol Cooled Units instead of the standard 2-way condenser water valves.

GENERAL ENGINEERING DETAILS

Downflow or Upflow Model									
Model Size		15	20	30	40	60	70	80	100
All Heat Reject Types									
Coil Data									
Coil Face Area – DX Type	m ²	0.68	0.68	1.44	1.44	2.17	2.17	2.17	N/A
Coil Face Area – Chilled Water Type	m ²	0.68	0.68	1.44	1.44	2.17	2.17	2.17	2.88
Rows	-	3	4	3	4	4	4	5	5
Coil Drain Connection	mm	19	19	19	19	19	19	19	19
Air Side Data									
No. of Fans	-	1	1	2	2	3	3	3	4
Air Volume	m ³ /s	1.39	1.67	2.78	3.33	4.17	5.00	5.42	7.2
	m ³ /hr	5,000	6,000	10,000	12,000	15,000	18,000	19,500	26,000
External Static Pressure ESP	Pa	50	50	50	50	50	50	50	50
Fan Motor	kW	1.1	1.1	1.1	1.1	1.1	1.1	1.5	1.5
No. of Motors	-	1	1	2	2	3	3	3	4
Filter Data									
Downflow Filter Size Code	-	1	1	2	2	2	2	2	2
Downflow Filter Quantity	No.	4	4	4	4	6	6	6	8
Upflow Filter Size Code	-	1	1	1	1	1	1	1	1
Upflow Filter Quantity	No.	1	1	2	2	3	3	3	4
Humidifier Data									
Inlet Connection	BSPM	¾"	¾"	¾"	¾"	¾"	¾"	¾"	¾"
Drain Connection	BSPF	¾"	¾"	¾"	¾"	¾"	¾"	¾"	¾"
Water Feed Pressure	Bar	1-10	1-10	1-10	1-10	1-10	1-10	1-10	1-10
French Degrees Water Hardness	-	15-30	15-30	15-30	15-30	15-30	15-30	15-30	15-30
Noise Data									
Freefield SPL	dB(A)	53	55	56	57	59	61	62	63
Air Cooled									
Discharge Connection Size	inch	5/8"	5/8"	5/8"	7/8"	7/8"	7/8"	1 1/8"	N/A
Liquid Connection Size	inch	1/2"	1/2"	1/2"	1/2"	5/8"	5/8"	5/8"	N/A
Condenser Conns. Inlet/Outlet 30°C	mm	20/18	20/18	20/18	20/18	24/22	28/22	35/28	N/A
Condenser Conns. Inlet/Outlet 35°C	mm	20/18	22/20	20/18	22/20	28/22	35/28	35/28	N/A
Condenser Conns. Inlet/Outlet 40°C	mm	22/20	24/22	22/20	24/22	35/28	35/28	42/35	N/A
Condenser Conns. Inlet/Outlet 45°C	mm	24/22	35/28	24/22	35/28	42/35	42/35	42/35	N/A
Scroll Compressor x 2 No. - 50Hz	-	ZR 72	ZR 90	ZR 72	ZR 90	ZR 12	ZR 16	ZR 19	N/A
Scroll Compressor x 2 No. - 60Hz	-	ZR 61	ZR 81	ZR 61	ZR 81	ZR 11	ZR 12	ZR 16	N/A
Water & Glycol Cooled									
Condenser Water F&R Pipe Size	BSPM	1"	1 1/4"	1"	1 1/4"	1 1/4"	1 1/4"	1 1/4"	N/A
Drycooler Conns. Inlet/Outlet 30°C	BSPM	1 1/4"	1 1/4"	1 1/2"	2"	2"	2"	2"	N/A
Drycooler Conns. Inlet/Outlet 35°C	BSPM	1 1/4"	1 1/4"	1 1/2"	1 1/2"	1 1/2"	2"	2"	N/A
Drycooler Conns. Inlet/Outlet 40°C	BSPM	1 1/4"	1 1/4"	1 1/2"	1 1/2"	2"	2"	2"	N/A
Drycooler Conns. Inlet/Outlet 45°C	BSPM	1 1/4"	1 1/2"	1 1/2"	1 1/2"	2"	2 1/2"	2 1/2"	N/A
Scroll Compressor x 2 No. - 50Hz	-	ZR 72	ZR 90	ZR 72	ZR 90	ZR 12	ZR 16	ZR 19	N/A
Scroll Compressor x 2 No. - 60Hz	-	ZR 61	ZR 81	ZR 61	ZR 81	ZR 11	ZR 12	ZR 16	N/A
Chilled Water Cooled									
Chilled Water F&R Pipe Size	BSPM	1"	1"	1 1/4"	1 1/2"	2"	2"	2"	1 1/2"
Control Valve Size	mm	25	25	32	32	40	40	40	40
Control Valve Quantity	No.	1	1	1	1	1	1	1	2
Control Valve Kv	-	10.0	10.0	16.0	16.0	25.0	25.0	25.0	25.0

Notes

1. Indoor unit Freefield SPL dBA levels are measured at 3m.
2. Downflow Filter Size Codes: 1 = 370 x 530mm, 2 = 740 x 530mm. Upflow Filter Size Codes: 1 = 840 x 530mm
3. All upflow filters are 100mm thick and all downflow filters are 50mm thick.
4. All filters have an efficiency rating of G4 in accordance with EU Standard EN779.
5. Water feed electrical conductivity for the humidifier should be in the range of 400 - 800 microsiemens.
6. The 100-Model chilled water unit has 2 sets of 1 1/2" flow and return connections, 1 per module/section.

AIR COOLED SYSTEM SCHEMATIC

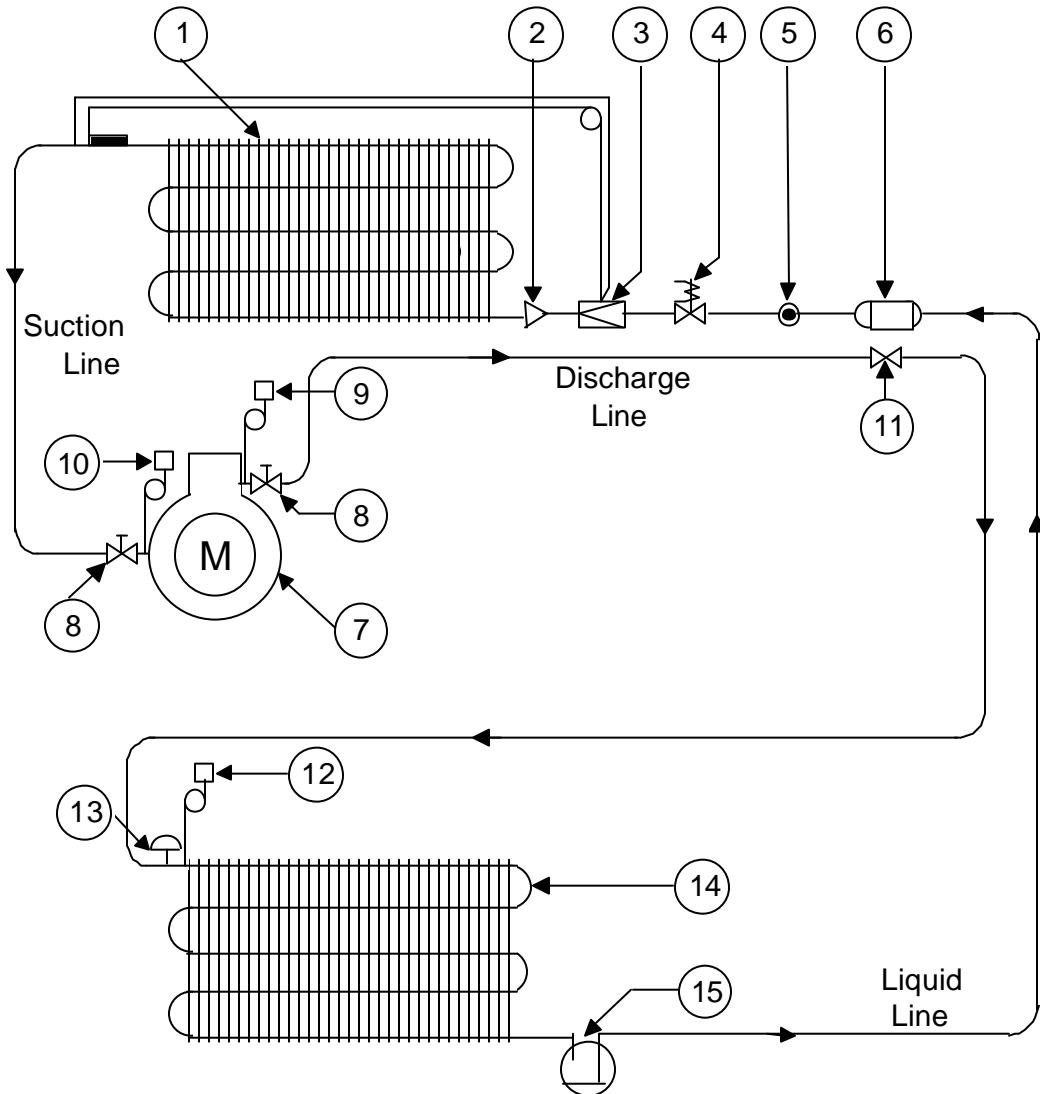

System Components

1. Evaporator Coil.
2. Liquid Distributor.
3. Thermostatic Expansion Valve (externally equalised).
4. Liquid Line Solenoid Valve (optional).
5. Liquid Sight Glass (including moisture indicator).
6. Filter Drier.
7. Compressor.
8. Compressor Service Valves.
9. High Pressure Switch (manual reset).
10. Low Pressure Switch (automatic reset).
11. Check Valve (See Note).
12. Fan speed Controller (pressure operated head pressure control, if fitted).
13. Pressure relief Valve (See Note).
14. Air Cooled Condenser.
15. Liquid Receiver (See Note).

Note: Items 11, 13 and 15 are supplied by others and field fitted by others.

WATER/GLYCOL COOLED SYSTEM SCHEMATIC

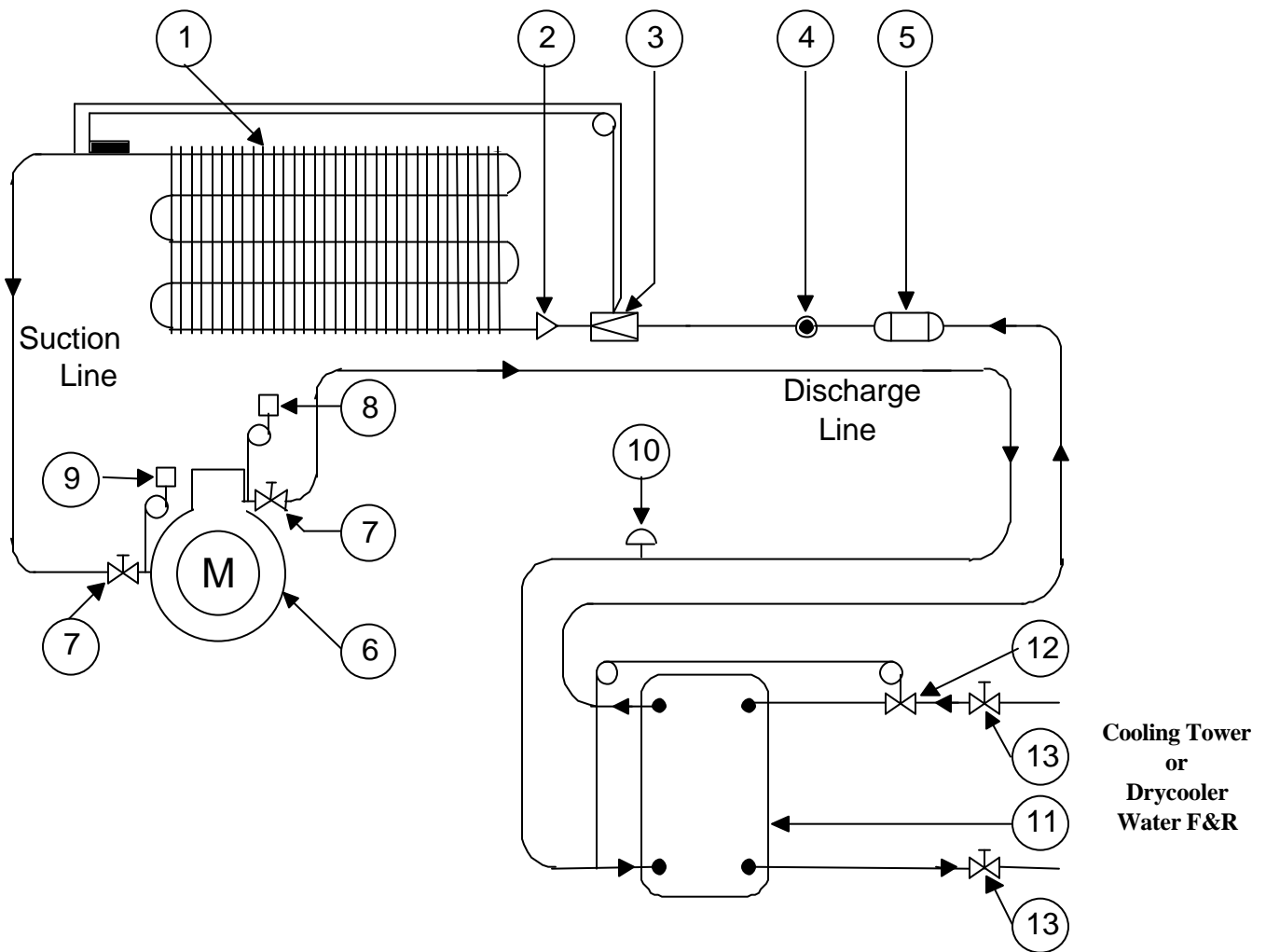

System Components

1. Evaporator Coil.
2. Liquid Distributor.
3. Thermostatic Expansion Valve (externally equalised).
4. Liquid Sight Glass (including moisture indicator).
5. Filter Drier.
6. Compressor.
7. Compressor Service Valves.
8. High Pressure Switch (manual reset).
9. Low Pressure Switch (automatic reset).
10. Pressure Relief Valve.
11. Plate Heat Exchanger.
12. Water Regulating Valve.
13. Isolating Valves.

Note: Item 13 is field fitted by others.

CHILLED WATER SYSTEM SCHEMATIC

3 Way Valve System

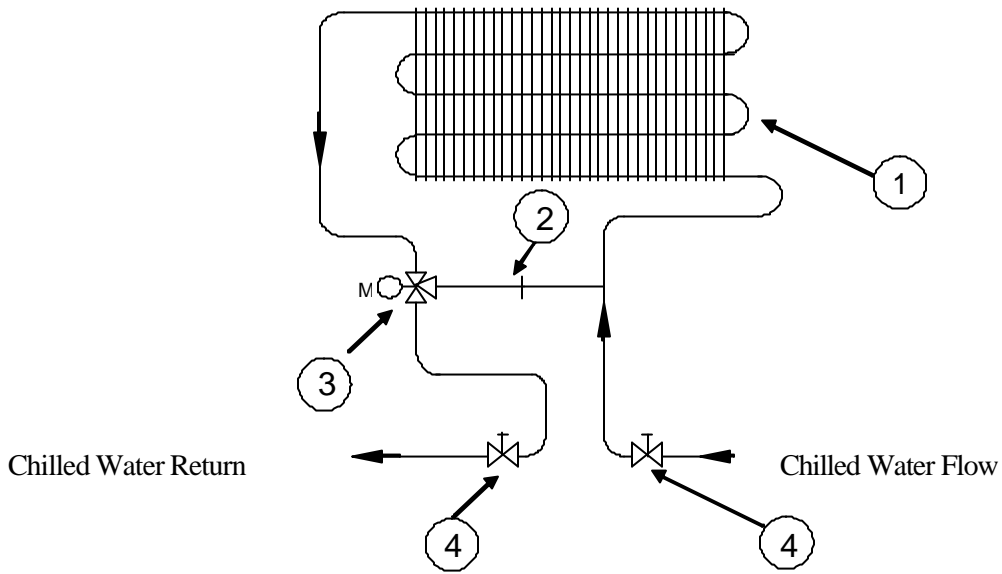

2 Way Valve System

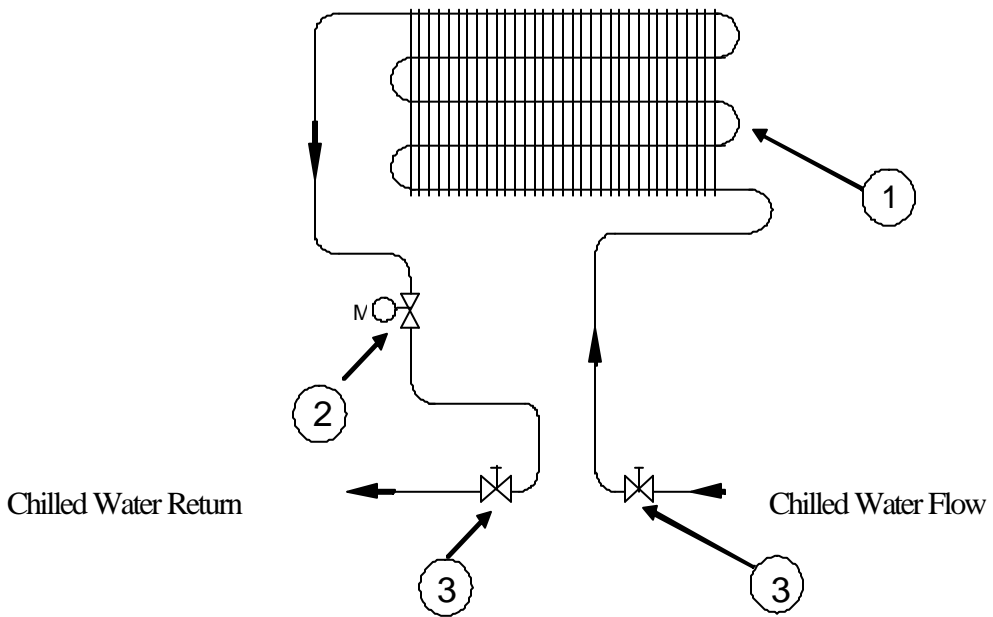

System Components

- | 3 Way Valve System | 2 Way Valve System |
|--------------------------|------------------------|
| 1 Chilled Water Coil | Chilled Water Coil |
| 2 Balancing Orifice | 2 Way Modulating Valve |
| 3 3 Way Modulating Valve | Isolating Valves |
| 4 Isolating Valves | |

Note: Isolating valves are field fitted by others.

AIR COOLED UNITS - COOLING CAPACITIES 50Hz

Model: DPA / FPA		15	20	30	40	60	70	80
Air On: 22°C, 50% RH								
Total Capacity	kW	16.7	21.1	33.6	42.6	60.5	72.4	86.1
Sensible Capacity	kW	14.8	18.5	30.1	37.3	51.9	63.3	72.6
Air On: 24°C, 50% RH								
Total Capacity	kW	17.8	22.4	35.8	45.3	64.2	76.4	91.7
Sensible Capacity	kW	15.2	19.2	31.1	38.9	52.6	63.9	74.9
Scroll Compressor	-	ZR72K	ZR90K	ZR72K	ZR90K	ZR12M	ZR16M	ZR19M
Compressor Input Power	kW	4.9	6.3	4.9	6.3	8.6	10.8	13.0
Compressor Quantity	No.	1	1	2	2	2	2	2
Airflow	m ³ /s	1.39	1.67	2.78	3.33	4.17	5.00	5.42
No. of Fans	No.	1	1	2	2	3	3	3
Fan Motor	kW	1.1	1.1	1.1	1.1	1.1	1.1	1.5
No. of Motors	No.	1	1	2	2	3	3	3
Electric Reheat	kW	7.5	7.5	15.0	15.0	22.5	22.5	22.5
No. of Steps	No.	1	1	2	2	3	3	3
Humidifier Capacity	kg/hr	3.0	3.0	8.0	8.0	8.0	8.0	8.0
Humidifier Power	kW	2.2	2.2	5.8	5.8	5.8	5.8	5.8

AIR COOLED UNITS - COOLING CAPACITIES 60Hz

Model: DPA / FPA		15	20	30	40	60	70	80
Air On: 22°C, 50% RH								
Total Capacity	kW	17.0	22.7	34.1	46.0	61.2	71.0	84.4
Sensible Capacity	kW	15.0	19.5	30.4	39.3	52.3	62.5	71.7
Air On: 24°C, 50% RH								
Total Capacity	kW	18.1	24.3	36.4	49.0	65.6	74.9	90.0
Sensible Capacity	kW	15.4	20.1	31.4	40.8	53.3	63.1	74.1
Scroll Compressor	-	ZR61K	ZR81K	ZR61K	ZR81K	ZR11M	ZR12M	ZR16M
Compressor Input Power	kW	4.8	6.4	7.3	6.4	8.8	10.0	12.4
Compressor Quantity	No.	1	1	2	2	2	2	2
Airflow	m ³ /s	1.39	1.67	2.78	3.33	4.17	5.00	5.42
No. of Fans	No.	1	1	2	2	3	3	3
Fan Motor	kW	1.1	1.1	1.1	1.1	1.1	1.1	1.5
No. of Motors	No.	1	1	2	2	3	3	3
Electric Reheat	kW	7.5	7.5	15.0	15.0	22.5	22.5	22.5
No. of Steps	No.	1	1	2	2	3	3	3
Humidifier Capacity	kg/hr	3.0	3.0	8.0	8.0	8.0	8.0	8.0
Humidifier Power	kW	2.2	2.2	5.8	5.8	5.8	5.8	5.8

Notes

1. Capacities are based on R407C refrigerant.
2. For capacities at other conditions, please refer to the Factory.
3. All units are R22 compatible.
4. Units are also available for R134A applications, please contact the factory.

WATER COOLED UNITS - COOLING CAPACITIES 50Hz

Model: DPW / FPW		15	20	30	40	60	70	80
Air On: 22°C, 50% RH								
Total Capacity	kW	17.8	22.5	35.6	45.4	63.2	76.3	90.6
Sensible Capacity	kW	15.5	19.3	31.3	39.0	53.5	65.6	75.3
Water Flow	l/s	0.6	0.8	1.3	1.6	2.2	2.9	3.5
Unit Pressure Drop	kPa	49	51	89	51	59	69	69
Air On: 24°C, 50% RH								
Total Capacity	kW	18.9	23.9	37.9	48.3	67.7	80.6	96.6
Sensible Capacity	kW	15.9	20.0	32.2	40.4	54.4	66.2	77.3
Water Flow	l/s	0.6	0.8	1.3	1.6	2.2	2.9	3.5
Unit Pressure Drop	kPa	49	51	49	51	59	69	69
Scroll Compressor	-	ZR72K	ZR90K	ZR72K	ZR90K	ZR12M	ZR16M	ZR19M
Compressor Input Power	kW	4.9	6.3	4.9	6.3	8.6	10.8	13.0
Compressor Quantity	No.	1	1	2	2	2	2	2
Airflow	m ³ /s	1.39	1.67	2.78	3.33	4.17	5.00	5.42
No. of Fans	No.	1	1	2	2	3	3	3
Fan Motor	kW	1.1	1.1	1.1	1.1	1.1	1.1	1.5
No. of Motors	No.	1	1	2	2	3	3	3
Electric Reheat	kW	7.5	7.5	15.0	15.0	22.5	22.5	22.5
No. of Steps	No.	1	1	2	2	3	3	3
Humidifier Capacity	kg/hr	3.0	3.0	8.0	8.0	8.0	8.0	8.0
Humidifier Power	kW	2.2	2.2	5.8	5.8	5.8	5.8	5.8

WATER COOLED UNITS - COOLING CAPACITIES 60Hz

Model: DPW / FPW		15	20	30	40	60	70	80
Air On: 22°C, 50% RH								
Total Capacity	kW	18.0	24.2	36.1	48.9	64.8	74.9	89.2
Sensible Capacity	kW	15.7	20.4	31.6	41.1	54.4	64.8	74.4
Water Flow	l/s	0.6	0.8	1.3	1.6	2.2	2.9	3.5
Unit Pressure Drop	kPa	49	51	49	51	59	69	69
Air On: 24°C, 50% RH								
Total Capacity	kW	19.3	25.8	38.5	52.1	69.3	79.0	95.1
Sensible Capacity	kW	16.1	20.9	32.5	42.3	55.2	65.3	76.6
Water Flow	l/s	0.6	0.8	1.3	1.6	2.2	2.9	3.5
Unit Pressure Drop	kPa	49	51	49	51	59	69	69
Scroll Compressor	-	ZR61K	ZR81K	ZR61K	ZR81K	ZR11M	ZR12M	ZR16M
Compressor Input Power	kW	4.8	6.4	7.3	6.4	8.8	10.0	12.4
Compressor Quantity	No.	1	1	2	2	2	2	2
Airflow	m ³ /s	1.39	1.67	2.78	3.33	4.17	5.00	5.42
No. of Fans	No.	1	1	2	2	3	3	3
Fan Motor	kW	1.1	1.1	1.1	1.1	1.1	1.1	1.5
No. of Motors	No.	1	1	2	2	3	3	3
Electric Reheat	kW	7.5	7.5	15.0	15.0	22.5	22.5	22.5
No. of Steps	No.	1	1	2	2	3	3	3
Humidifier Capacity	kg/hr	3.0	3.0	8.0	8.0	8.0	8.0	8.0
Humidifier Power	kW	2.2	2.2	5.8	5.8	5.8	5.8	5.8

Notes

1. Capacities are based on R407C refrigerant. For capacities at other conditions, please refer to the Factory.
2. All units are R22 compatible.
3. Units are also available for R134A applications, please contact the factory.

GLYCOL COOLED UNITS - COOLING CAPACITIES 50Hz

Model: DPG / FPG		15	20	30	40	60	70	80
Air On: 22°C, 50% RH								
Total Capacity	kW	16.0	20.2	32.3	40.7	57.4	69.6	82.8
Sensible Capacity	kW	14.3	17.9	29.2	36.2	50.1	61.7	70.7
Air On: 24°C, 50% RH								
Total Capacity	kW	17.0	21.4	34.3	43.3	61.5	73.4	88.1
Sensible Capacity	kW	14.8	18.7	30.3	37.8	51.2	62.3	73.1
Scroll Compressor	-	ZR72K	ZR90K	ZR72K	ZR90K	ZR12M	ZR16M	ZR19M
Compressor Input Power	kW	4.9	6.3	4.9	6.3	8.6	10.8	13.0
Compressor Quantity	No.	1	1	2	2	2	2	2
Airflow	m ³ /s	1.39	1.67	2.78	3.33	4.17	5.00	5.42
No. of Fans	No.	1	1	2	2	3	3	3
Fan Motor	kW	1.1	1.1	1.1	1.1	1.1	1.1	1.5
No. of Motors	No.	1	1	2	2	3	3	3
Electric Reheat	kW	7.5	7.5	15.0	15.0	22.5	22.5	22.5
No. of Steps	No.	1	1	2	2	3	3	3
Humidifier Capacity	kg/hr	3.0	3.0	8.0	8.0	8.0	8.0	8.0
Humidifier Power	kW	2.2	2.2	5.8	5.8	5.8	5.8	5.8
Glycol Flow (25%)	l/s	0.7	0.8	1.4	1.6	2.4	2.8	3.6
Unit Pressure Drop	kPa	55	51	55	51	65	65	72
Drycooler Press. Drop	kPa	33	18	23	28	20	26	25

GLYCOL COOLED UNITS - COOLING CAPACITIES 60Hz

Model: DPG / FPG		15	20	30	40	60	70	80
Air On: 22°C, 50% RH								
Total Capacity	kW	16.2	21.7	32.7	43.9	58.8	68.4	81.2
Sensible Capacity	kW	14.5	18.9	29.5	38.1	50.9	61.0	69.8
Air On: 24°C, 50% RH								
Total Capacity	kW	17.3	23.2	34.9	46.8	63.0	72.1	86.5
Sensible Capacity	kW	15.0	19.6	30.6	39.6	52.0	61.6	72.3
Scroll Compressor	-	ZR61K	ZR81K	ZR61K	ZR81K	ZR11M	ZR12M	ZR16M
Compressor Input Power	kW	4.8	6.4	7.3	6.4	8.8	10.0	12.4
Compressor Quantity	No.	1	1	2	2	2	2	2
Airflow	m ³ /s	1.39	1.67	2.78	3.33	4.17	5.00	5.42
No. of Fans	No.	1	1	2	2	3	3	3
Fan Motor	kW	1.1	1.1	1.1	1.1	1.1	1.1	1.5
No. of Motors	No.	1	1	2	2	3	3	3
Electric Reheat	kW	7.5	7.5	15.0	15.0	22.5	22.5	22.5
No. of Steps	No.	1	1	2	2	3	3	3
Humidifier Capacity	kg/hr	3.0	3.0	8.0	8.0	8.0	8.0	8.0
Humidifier Power	kW	2.2	2.2	5.8	5.8	5.8	5.8	5.8
Glycol Flow (25%)	l/s	0.7	0.8	1.4	1.6	2.4	2.8	3.6
Unit Pressure Drop	kPa	55	51	55	51	65	65	72
Drycooler Press. Drop	kPa	33	18	23	28	20	26	25

Notes

1. Capacities are based on R407C refrigerant. For capacities at other conditions, please refer to the Factory.
2. All units are R22 compatible.
3. Units are also available for R134A applications, please contact the factory.

CHILLED WATER COOLED UNITS - COOLING CAPACITIES 50/60Hz

Model: DPC / FPC		15	20	30	40	60	70	80	100
Air On: 22°C, 50% RH									
Total Capacity	kW	15.4	21.6	32.3	44.1	56.5	64.5	77.9	100.4
Sensible Capacity	kW	14.9	20.1	30.6	40.7	52.1	60.4	72.9	95.8
Chilled Water Flow	l/s	0.6	0.9	1.3	1.8	2.2	2.6	3.1	4.0
Unit Pressure Drop	kPa	21	44	36	57	34	47	71	76
Air On: 24°C, 50% RH									
Total Capacity	kW	19.0	26.7	40.0	49.1	69.8	79.7	87.0	111.8
Sensible Capacity	kW	16.5	22.3	34.0	40.8	57.9	72.9	73.1	95.8
Chilled Water Flow	l/s	0.8	1.0	1.3	2.0	2.8	3.2	3.5	4.4
Unit Pressure Drop	kPa	35	54	52	75	54	69	96	84
Airflow	m ³ /s	1.39	1.67	2.78	3.33	4.17	5.00	5.42	7.2
No. of Fans	No.	1	1	2	2	3	3	3	4
Fan Motor	kW	1.1	1.1	1.1	1.1	1.1	1.1	1.5	1.5
No. of Motors	No.	1	1	2	2	3	3	3	4
Electric Reheat	kW	7.5	7.5	15.0	15.0	22.5	22.5	22.5	22.5
No. of Steps	No.	1	1	2	2	3	3	3	1
Humidifier Capacity	kg/hr	3.0	3.0	8.0	8.0	8.0	8.0	8.0	8.0
Humidifier Power	kW	2.2	2.2	5.8	5.8	5.8	5.8	5.8	5.8

Note

1. Capacities are based on a 6°C chilled water coil entering temperature & the tabulated flow rate.

ELECTRICAL DETAILS - 400V/3PH/50Hz

Air Cooled Models

Model	15	20	30	40	60	70	80
Controls FLA	1.0	1.0	1.0	1.0	1.0	1.0	1.0
Fans FLA	2.7	2.7	5.4	5.4	8.1	8.1	11.1
Reheat FLA	10.8	10.8	21.6	21.6	32.4	32.4	32.4
Humidifier FLA	3.2	3.2	8.4	8.4	8.4	8.4	8.4
Scroll Compressor FLA	8.7	12.5	17.4	23.0	31.6	37.0	45.2
Condenser FLA @ 30°C	1.4	1.4	2.8	2.8	4.2	4.2	13.6
Condenser FLA @ 35°C	1.4	1.4	2.8	2.8	4.2	13.6	13.6
Condenser FLA @ 40°C	1.4	2.1	2.8	4.2	13.6	13.6	20.4
Condenser FLA @ 45°C	2.1	6.8	4.2	13.6	20.4	20.4	20.4

Water Cooled Models

Model	15	20	30	40	60	70	80
Controls FLA	1.0	1.0	1.0	1.0	1.0	1.0	1.0
Fans FLA	2.7	2.7	5.4	5.4	8.1	8.1	11.1
Reheat FLA	10.8	10.8	21.6	21.6	32.4	32.4	32.4
Humidifier FLA	3.2	3.2	8.4	8.4	8.4	8.4	8.4
Scroll Compressor FLA	8.7	12.5	17.4	23.0	31.6	37.0	45.2

Glycol Cooled Models

Model	15	20	30	40	60	70	80
Controls FLA	1.0	1.0	1.0	1.0	1.0	1.0	1.0
Fans FLA	2.7	2.7	5.4	5.4	8.1	8.1	11.1
Reheat FLA	10.8	10.8	21.6	21.6	32.4	32.4	32.4
Humidifier FLA	3.2	3.2	8.4	8.4	8.4	8.4	8.4
Scroll Compressor FLA	8.7	12.5	17.4	23.0	31.6	37.0	45.2
Drycooler FLA @ 30°C	2.6	2.6	3.9	3.9	14.4	14.4	14.4
Drycooler FLA @ 35°C	2.6	2.6	3.9	9.6	9.6	14.4	14.4
Drycooler FLA @ 40°C	2.6	2.6	3.9	9.6	14.4	14.4	14.4
Drycooler FLA @ 45°C	2.6	2.6	9.6	9.6	14.4	19.2	19.2

Chilled Water Models

Model	15	20	30	40	60	70	80	100
Controls FLA	1.0	1.0	1.0	1.0	1.0	1.0	1.0	1.0
Fans FLA	2.7	2.7	5.4	5.4	8.1	8.1	11.1	14.8
Reheat FLA	10.8	10.8	21.6	21.6	32.4	32.4	32.4	32.4
Humidifier FLA	3.2	3.2	8.4	8.4	8.4	8.4	8.4	3.2

Notes

1. FLA = Full Load Amps.
2. Unit maximum FLA is the total of the components, which operate during maximum electrical load conditions. For full function units with humidifier & electric reheat the maximum FLA would be in dehumidification mode i.e. cooling + reheat.
3. In dehumidification in Twin Circuit Units, calculate the max FLA based on a single compressor FLA as only one compressor operates in dehumidification mode.
4. In cooling and humidification mode, calculate the max FLA based on dual compressor FLA as both compressors and the humidifier operate in this mode.
5. For 30°C & 35°C ambients a single condenser with split headers is used. The fans are all single phase.
6. For 40°C & 45°C ambients two condensers are required. The condenser fan FLA is based on the first fan being 1 phase (for pressure activated fan speed control) with the remaining fans being 3 phase (pressure switch activated).
7. For Glycol Cooled Units with Drycoolers, please note that Drycooler Fans are all 3 phase on/off. Head pressure control is carried out by a water regulating valve in the indoor unit.

ELECTRICAL DETAILS - 220V/3PH/60Hz

Air Cooled Models

Model	15	20	30	40	60	70	80
Controls FLA	1.0	1.0	1.0	1.0	1.0	1.0	1.0
Fans FLA	4.9	4.9	9.8	9.8	14.7	14.7	20.2
Reheat FLA	19.6	19.6	39.3	39.3	58.8	58.8	58.8
Humidifier FLA	5.7	5.7	15.3	15.3	15.3	15.3	15.3
Scroll Compressor FLA	16.3	21.3	32.6	42.6	54.2	57.4	67.2
Condenser FLA @ 30°C	1.4	1.4	2.8	2.8	4.2	4.2	13.6
Condenser FLA @ 35°C	1.4	1.4	2.8	2.8	4.2	13.6	13.6
Condenser FLA @ 40°C	1.4	2.1	2.8	4.2	13.6	13.6	20.4
Condenser FLA @ 45°C	2.1	6.8	4.2	13.6	20.4	20.4	20.4

Water Cooled Models

Model	15	20	30	40	60	70	80
Controls FLA	1.0	1.0	1.0	1.0	1.0	1.0	1.0
Fans FLA	4.9	4.9	9.8	9.8	14.7	14.7	20.2
Reheat FLA	19.6	19.6	39.3	39.3	58.8	58.8	58.8
Humidifier FLA	5.7	5.7	15.3	15.3	15.3	15.3	15.3
Scroll Compressor FLA	16.3	21.3	32.6	42.6	54.2	57.4	67.2

Glycol Models

Model	15	20	30	40	60	70	80
Controls FLA	1.0	1.0	1.0	1.0	1.0	1.0	1.0
Fans FLA	4.9	4.9	9.8	9.8	14.7	14.7	20.2
Reheat FLA	19.6	19.6	39.3	39.3	58.8	58.8	58.8
Humidifier FLA	5.7	5.7	15.3	15.3	15.3	15.3	15.3
Scroll Compressor FLA	16.3	21.3	32.6	42.6	54.2	57.4	67.2
Drycooler FLA @ 30°C	7.4	7.4	11.1	11.1	17.4	17.4	17.4
Drycooler FLA @ 35°C	7.4	7.4	11.1	11.6	11.6	17.4	17.4
Drycooler FLA @ 40°C	7.4	7.4	11.1	11.6	17.4	17.4	17.4
Drycooler FLA @ 45°C	7.4	7.4	11.6	11.6	17.4	23.2	23.2

Chilled Water Models

Model	15	20	30	40	60	70	80	100
Controls FLA	1.0	1.0	1.0	1.0	1.0	1.0	1.0	1.0
Fans FLA	4.9	4.9	9.8	9.8	14.7	14.7	20.2	27.0
Reheat FLA	19.6	19.6	39.3	39.3	58.8	58.8	58.8	58.8
Humidifier FLA	5.7	5.7	15.3	15.3	15.3	15.3	15.3	5.7

Notes

1. FLA = Full Load Amps.
2. Unit maximum FLA is the total of the components, which operate during maximum electrical load conditions. For full function units with humidifier & electric reheat the maximum FLA would be in dehumidification mode i.e. cooling + reheat.
3. In dehumidification in Twin Circuit Units, calculate the max FLA based on a single compressor FLA as only one compressor operates in dehumidification mode.
4. In cooling and humidification mode, calculate the max FLA based on dual compressor FLA as both compressors and the humidifier operate in this mode.
5. For 30°C & 35°C ambients a single condenser with split headers is used. The fans are all single phase.
6. For 40°C & 45°C ambients two condensers are required. The condenser fan FLA is based on the first fan being 1 phase (for pressure activated fan speed control) with the remaining fans being 3 phase (pressure switch activated).
7. For Glycol Cooled Units with Drycoolers, please note that Drycooler Fans are all 3 phase on/off. Head pressure control is carried out by a water regulating valve in the indoor unit.

ELECTRICAL DETAILS - 380V/3PH/60Hz

Air Cooled Models

Model	15	20	30	40	60	70	80
Controls FLA	1.0	1.0	1.0	1.0	1.0	1.0	1.0
Fans FLA	2.8	2.8	5.7	5.7	8.5	8.5	11.7
Reheat FLA	11.4	11.4	22.8	22.8	34.2	34.2	34.2
Humidifier FLA	3.3	3.3	8.8	8.8	8.8	8.8	8.8
Scroll Compressor FLA	9.4	12.3	18.8	24.6	31.4	33.2	39
Condenser FLA @ 30°C	1.2	1.2	2.4	2.4	3.6	3.6	8.4
Condenser FLA @ 35°C	1.2	1.2	2.4	2.4	3.6	8.4	12.6
Condenser FLA @ 40°C	1.2	1.8	2.4	3.6	8.4	8.4	12.6
Condenser FLA @ 45°C	1.8	4.2	3.6	8.4	12.6	12.6	12.6

Water Cooled Models

Model	15	20	30	40	60	70	80
Controls FLA	1.0	1.0	1.0	1.0	1.0	1.0	1.0
Fans FLA	2.8	2.8	5.7	5.7	8.5	8.5	11.7
Reheat FLA	11.4	11.4	22.8	22.8	34.2	34.2	34.2
Humidifier FLA	3.3	3.3	8.8	8.8	8.8	8.8	8.8
Scroll Compressor FLA	9.4	12.3	18.8	24.6	31.4	33.2	39

Glycol Cooled Models

Model	15	20	30	40	60	70	80
Controls FLA	1.0	1.0	1.0	1.0	1.0	1.0	1.0
Fans FLA	2.8	2.8	5.7	5.7	8.5	8.5	11.7
Reheat FLA	11.4	11.4	22.8	22.8	34.2	34.2	34.2
Humidifier FLA	3.3	3.3	8.8	8.8	8.8	8.8	8.8
Scroll Compressor FLA	9.4	12.3	18.8	24.6	31.4	33.2	39
Drycooler FLA @ 30°C	4.2	4.2	6.3	6.3	10.2	10.2	10.2
Drycooler FLA @ 35°C	4.2	4.2	6.3	6.8	6.8	10.2	10.2
Drycooler FLA @ 40°C	4.2	4.2	6.3	6.8	10.2	10.2	10.2
Drycooler FLA @ 45°C	4.2	4.2	6.8	6.8	10.2	13.6	13.6

Chilled Water Models

Model	15	20	30	40	60	70	80	100
Controls FLA	1.0	1.0	1.0	1.0	1.0	1.0	1.0	1.0
Fans FLA	2.8	2.8	5.7	5.7	8.5	8.5	11.7	15.5
Reheat FLA	11.4	11.4	22.8	22.8	34.2	34.2	34.2	34.2
Humidifier FLA	4.4	4.4	8.8	8.8	11.0	13.4	13.4	13.4

Notes

1. FLA = Full Load Amps.
2. Unit maximum FLA is the total of the components, which operate during maximum electrical load conditions. For full function units with humidifier & electric reheat the maximum FLA would be in dehumidification mode i.e. cooling + reheat.
3. In dehumidification in Twin Circuit Units, calculate the max FLA based on a single compressor FLA as only one compressor operates in dehumidification mode.
4. In cooling and humidification mode, calculate the max FLA based on dual compressor FLA as both compressors and the humidifier operate in this mode.
5. For 30°C & 35°C ambients a single condenser with split headers is used. The fans are all single phase.
6. For 40°C & 45°C ambients two condensers are required. The condenser fan FLA is based on the first fan being 1 phase (for pressure activated fan speed control) with the remaining fans being 3 phase (pressure switch activated).
7. For Glycol Cooled Units with Drycoolers, please note that Drycooler Fans are all 3 phase on/off. Head pressure control is carried out by a water regulating valve in the indoor unit.

ELECTRICAL DETAILS - 460V/3PH/60Hz

Air Cooled Models

Model	15	20	30	40	60	70	80
Controls FLA	1.0	1.0	1.0	1.0	1.0	1.0	1.0
Fans FLA	2.3	2.3	4.7	4.7	7.0	7.0	9.7
Reheat FLA	9.4	9.4	18.8	18.8	28.2	28.2	28.2
Humidifier FLA	2.7	2.7	7.2	7.2	7.2	7.2	7.2
Scroll Compressor FLA	7.8	10.2	15.6	20.4	26.0	27.4	32.2
Condenser FLA @ 30°C	1.8	1.8	3.2	3.2	4.8	4.8	8.4
Condenser FLA @ 35°C	1.8	1.8	3.2	3.2	4.8	8.4	8.4
Condenser FLA @ 40°C	1.8	1.8	3.2	4.8	8.4	8.4	12.6
Condenser FLA @ 45°C	2.4	4.2	4.8	8.4	12.6	12.6	12.6

Water Cooled Models

Model	15	20	30	40	60	70	80
Controls FLA	1.0	1.0	1.0	1.0	1.0	1.0	1.0
Fans FLA	2.3	2.3	4.7	4.7	7.0	7.0	9.7
Reheat FLA	9.4	9.4	18.8	18.8	28.2	28.2	28.2
Humidifier FLA	2.7	2.7	7.2	7.2	7.2	7.2	7.2
Scroll Compressor FLA	7.8	10.2	15.6	20.4	26.0	27.4	32.2

Glycol Cooled Models

Model	15	20	30	40	60	70	80
Controls FLA	1.0	1.0	1.0	1.0	1.0	1.0	1.0
Fans FLA	2.3	2.3	4.7	4.7	7.0	7.0	9.7
Reheat FLA	9.4	9.4	18.8	18.8	28.2	28.2	28.2
Humidifier FLA	2.7	2.7	7.2	7.2	7.2	7.2	7.2
Scroll Compressor FLA	7.8	10.2	15.6	20.4	26.0	27.4	32.2
Drycooler FLA @ 30°C	4.2	4.2	6.3	6.3	12.6	12.6	12.6
Drycooler FLA @ 35°C	4.2	4.2	6.3	8.4	8.4	12.6	12.6
Drycooler FLA @ 40°C	4.2	4.2	6.3	8.4	12.6	12.6	12.6
Drycooler FLA @ 45°C	4.2	4.2	8.4	8.4	12.6	16.8	16.8

Chilled Water Models

Model	15	20	30	40	60	70	80	100
Controls FLA	1.0	1.0	1.0	1.0	1.0	1.0	1.0	1.0
Fans FLA	2.3	2.3	4.7	4.7	7.0	7.0	9.7	12.9
Reheat FLA	9.4	9.4	18.8	18.8	28.2	28.2	28.2	28.2
Humidifier FLA	2.7	2.7	7.2	7.2	7.2	7.2	7.2	2.7

Notes

1. FLA = Full Load Amps.
2. Unit maximum FLA is the total of the components, which operate during maximum electrical load conditions. For full function units with humidifier & electric reheat the maximum FLA would be in dehumidification mode i.e. cooling + reheat.
3. In dehumidification in Twin Circuit Units, calculate the max FLA based on a single compressor FLA as only one compressor operates in dehumidification mode.
4. In cooling and humidification mode, calculate the max FLA based on dual compressor FLA as both compressors and the humidifier operate in this mode.
5. For 30°C & 35°C ambients a single condenser with split headers is used. The fans are all single phase.
6. For 40°C & 45°C ambients two condensers are required. The condenser fan FLA is based on the first fan being 1 phase (for pressure activated fan speed control) with the remaining fans being 3 phase (pressure switch activated).
7. For Glycol Cooled Units with Drycoolers, please note that Drycooler Fans are all 3 phase on/off. Head pressure control is carried out by a water regulating valve in the indoor unit.